

Synchrophasors for Validation of Distance Relay Settings: Real Time Digital Simulation and Field Results

Brian K. Johnson, Sal Jadid

Abstract—This paper proposes a method to measure transmission line parameters for protective relay settings. This method relies on synchronized phasor measurements taken at both ends of the line and compares them with the calculations from both the equivalent PI circuit and the distributed constant line parameters. This comparison determines which method provides more accuracy for determining relay settings. The method used for the calculation depends on whether the line is transposed or untransposed. The performance of the proposed method is verified using real time digital simulator and field data from Entergy phasor measurement units (PMUs) on a transmission line. This paper discusses the data collected from the PMUs and compares the calculation from the measured data with actual relay settings. Finally, the paper proposes a method for validating the relay settings.

I. INTRODUCTION

The offline calculation of transmission line impedance has long been used by engineers to determine appropriate distance relay settings. Accurate calculation is paramount for reliable distance relay operation and correct fault location. Transmission line impedance is estimated based on the tower configuration and physical properties of the conductor. These transmission line impedance estimates are based on assumptions and approximations such as ground resistivity and temperature.

Several methods have previously been proposed to identify transmission line parameters using phasor measurement units (PMUs). References [1] and [2] use the short line model for the calculation of only positive-sequence impedance, neglecting the shunt capacitance. Reference [3] includes the shunt capacitance but still only computes the positive-sequence impedance. For fully transposed transmission lines, the three sequence networks (positive, negative, and zero) are completely decoupled and the positive-sequence impedance parameters are determined by only the positive-sequence voltages and currents. However, for untransposed transmission lines or transmission lines that are not fully transposed, the three sequence networks are mutually coupled. Using only the positive-sequence measurements to estimate the positive-sequence parameters in these cases can generate inaccurate parameter estimates.

Reference [4] addresses zero-sequence parameters and describes the requirements for introducing an unbalance by tripping and reclosing a single-phase circuit breaker automatically or with an external voltage source. References [1] through [4] provide theoretical and simulation analysis, but they do not show practical implementation or a comparison of the results with data from field-installed synchrophasor units.

The method proposed in this paper validates the relay settings parameters derived from the positive- and zero-sequence impedances using measurements from synchronized phasors at both ends of a line. The method used for the calculation of the positive- and zero-sequence impedances depends on whether the line is transposed or untransposed. In the case of a transposed line, zero-sequence parameters are calculated from steady-state load conditions if there is sufficient unbalance in the measured voltage. The minimum amount of unbalance required to perform the calculation is characterized. The equations to calculate the positive- and zero-sequence impedances and shunt admittances for a transposed line can be clearly defined and then solved if there is sufficient standing zero-sequence voltage unbalance during normal system operation. The resulting set of equations is much more difficult to solve using measurements from steady-state operation if the line is untransposed.

In the case of untransposed lines or transposed lines without sufficient measured zero-sequence voltage unbalance, the parameters are calculated based on remote fault conditions involving ground in the system. These fault conditions are not necessarily on the line itself but can be anywhere that can generate enough zero-sequence unbalance. This unbalance is quantified.

In this paper, we use field data from Entergy PMUs installed on a 230 kV transmission line to compare these calculations with the relay settings derived from line constants programs. A method for checking the relay settings is proposed based on the parameter calculations from the PMUs.

This paper is organized as follows:

- Section II discusses line modeling and the models used for transmission lines.

Brian K. Johnson is with the University of Idaho, Moscow, ID USA
Sal Jadid is with Schweitzer Engineering Laboratories, Inc, Pullman, WA USA

- Section III discusses the calculation of parameters for both transposed and untransposed lines. Simulation using PSCAD™/EMTDC™ software is used to validate the results and verify the accuracy and limitations of the calculation method.
- Section IV summarizes and discusses the results from the RTDS real time digital simulator.
- Section IV discusses the setup of synchrophasors on an Entergy line.
- Section V discusses the results of the parameter calculation and compares them with the line constants and line distance settings that are presently programmed in the relay. A method for validation is then presented.

II. LINE MODELING

Fig. 1 shows the model of a three-phase transmission line with mutual impedance [5]. Similar circuit is needed in the positive, negative and zero sequence domain.

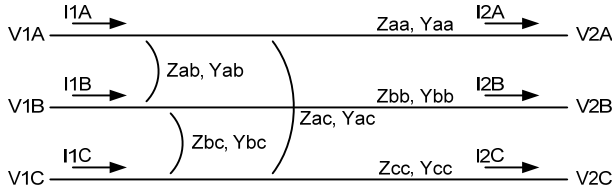

Fig. 1. Model of a three-phase transmission line with mutual impedance.

The transmission line is characterized by four parameters: series resistance R due to the conductor resistivity, shunt conductance G due to leakage currents between the phases and ground (this term is neglected because it has a very small impact on the types of studies that use the model), series inductor L due to the magnetic field surrounding the conductors, and shunt capacitance C due to the electric field between conductors.

The line parameters are defined by the shunt admittance matrix ($Y = jB \Omega^{-1}$ per mile) and the series impedance matrix ($Z = R + jX$ ohms per mile) for a lossless transmission line.

$$Y = \begin{bmatrix} Y_{aa} & Y_{ab} & Y_{ac} \\ Y_{ba} & Y_{bb} & Y_{bc} \\ Y_{ca} & Y_{cb} & Y_{cc} \end{bmatrix} \quad (1)$$

$$Z = \begin{bmatrix} Z_{aa} & Z_{ab} & Z_{ac} \\ Z_{ba} & Z_{bb} & Z_{bc} \\ Z_{ca} & Z_{cb} & Z_{cc} \end{bmatrix} \quad (2)$$

From (2), the symmetrical component matrix for an untransposed line can be computed (see [5]) using the symmetrical component transformation matrix and found to be the following:

$$Z_{\text{sym}} = \begin{bmatrix} Z_{00} & Z_{01} & Z_{02} \\ Z_{10} & Z_{11} & Z_{12} \\ Z_{20} & Z_{21} & Z_{22} \end{bmatrix} \quad (3)$$

where:

Z_{00} is the zero-sequence impedance.

Z_{11} is the positive-sequence impedance.

Z_{22} is the negative-sequence impedance.

Z_{01} is the mutual impedance between the zero and positive sequences.

Z_{02} is the mutual impedance between the zero and negative sequences.

Z_{21} is the mutual impedance between the negative and positive sequences.

For a fully transposed line, the off-diagonal terms in (2) are the mutual impedances between conductors and are equal. For a transposed line with a flat line configuration, the self-impedances and self-admittances are equal and provide the equations derived in [5].

$$Y = \begin{bmatrix} Y_{\text{self}} & Y_{\text{mutual}} & Y_{\text{mutual}} \\ Y_{\text{mutual}} & Y_{\text{self}} & Y_{\text{mutual}} \\ Y_{\text{mutual}} & Y_{\text{mutual}} & Y_{\text{self}} \end{bmatrix} \quad (4)$$

$$Z = \begin{bmatrix} Z_{\text{self}} & Z_{\text{mutual}} & Z_{\text{mutual}} \\ Z_{\text{mutual}} & Z_{\text{self}} & Z_{\text{mutual}} \\ Z_{\text{mutual}} & Z_{\text{mutual}} & Z_{\text{self}} \end{bmatrix} \quad (5)$$

The symmetrical component matrix for the transposed line is shown in (6).

$$Z_{012} = \begin{bmatrix} Z_0 & 0 & 0 \\ 0 & Z_1 & 0 \\ 0 & 0 & Z_2 \end{bmatrix} \quad (6)$$

In the symmetrical component matrix, the diagonal terms Z_0 , Z_1 , and Z_2 are the zero-, positive-, and negative-sequence impedances of the transmission line, respectively. Note that the off-diagonal terms are zero and indicate that there is no coupling between the positive-, negative-, and zero-sequence networks for the transposed line. The method that relies on the calculation of the impedance based on sequence components is only valid for transposed lines; however, off-diagonal terms are often approximated as zero for untransposed lines.

A. Equivalent PI Circuit

Fig. 2 shows the per-phase equivalent PI circuit of a three-phase transmission line [6].

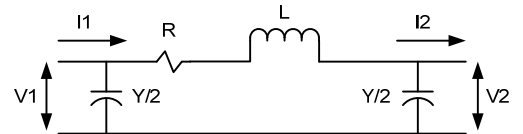

Fig. 2. Equivalent PI circuit of a three-phase transmission line.

The relationship between the currents and voltages is expressed using the following equations:

$$I1 + I2 = Y \cdot (V1 + V2) \quad (7)$$

$$V1 - V2 = Z \cdot Id \quad (8)$$

where:

$$Id = I1 - Y \cdot V1 \quad (9)$$

B. Steady-State Distributed Line Parameters

Fig. 3 shows the relationship between the current and voltage along the line in terms of the distributed parameters.

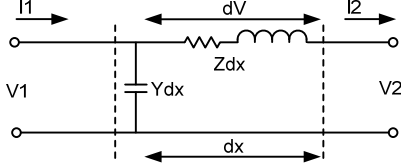

Fig. 3. Distributed model of a three-phase transmission line.

Equation (10) defines the model of the distributed parameter line.

$$\frac{dV}{dx} = Z \cdot I \quad \frac{dI}{dx} = Y \cdot V \quad (10)$$

The solution of (10), in terms of the sending and receiving voltage and currents [6], is defined as follows:

$$\begin{bmatrix} V1 \\ I1 \end{bmatrix} = \begin{bmatrix} \cosh(\Gamma l) & \sinh(\Gamma l) Z_0 \\ Y_0 \sinh(\Gamma l) & Y_0 \cosh(\Gamma l) Z_0 \end{bmatrix} \begin{bmatrix} V2 \\ I2 \end{bmatrix} \quad (11)$$

where:

$$\Gamma = (ZY)^{1/2}$$

$$Z_0 = \Gamma Y^{-1} = \Gamma^{-1} Z$$

$$Y_0 = Y \Gamma^{-1} = Z^{-1} \Gamma$$

C. Classification of Transmission Lines

Overhead lines can be classified according to length based on the approximations justified in their modeling [7]. They are classified at nominal frequency as follows:

- Short lines are shorter than 50 miles. They have negligible shunt capacitance and may be approximated as series impedance.
- Medium lines have lengths in the range of 50 to 125 miles. They can be approximated by the equivalent PI circuit. The majority of lines fall under this category, and this model is suitable for our analysis.
- Long lines are longer than 125 miles. For such lines, the distributed effects of the parameters can be significant and need to be represented by the distributed line parameters.

III. CALCULATION OF PARAMETERS

A. General Overview

The proposed method uses synchronized PMUs to obtain the phase voltages and currents at both ends of a line. These devices must have accurate time information. Global Positioning System (GPS) satellite-synchronized clocks with microsecond accuracy provide this information through demodulated IRIG-B signals. Proper time synchronization allows for obtaining time-synchronized samples of voltages and currents for use in calculating the impedance and admittance matrices.

B. Transposed Lines

1) Equivalent PI Circuit Analysis

A test setup using PSCAD/EMTDC software was used to simulate the conditions, and the setup validates the proposed solutions. Fig. 4 shows the test setup for the line.

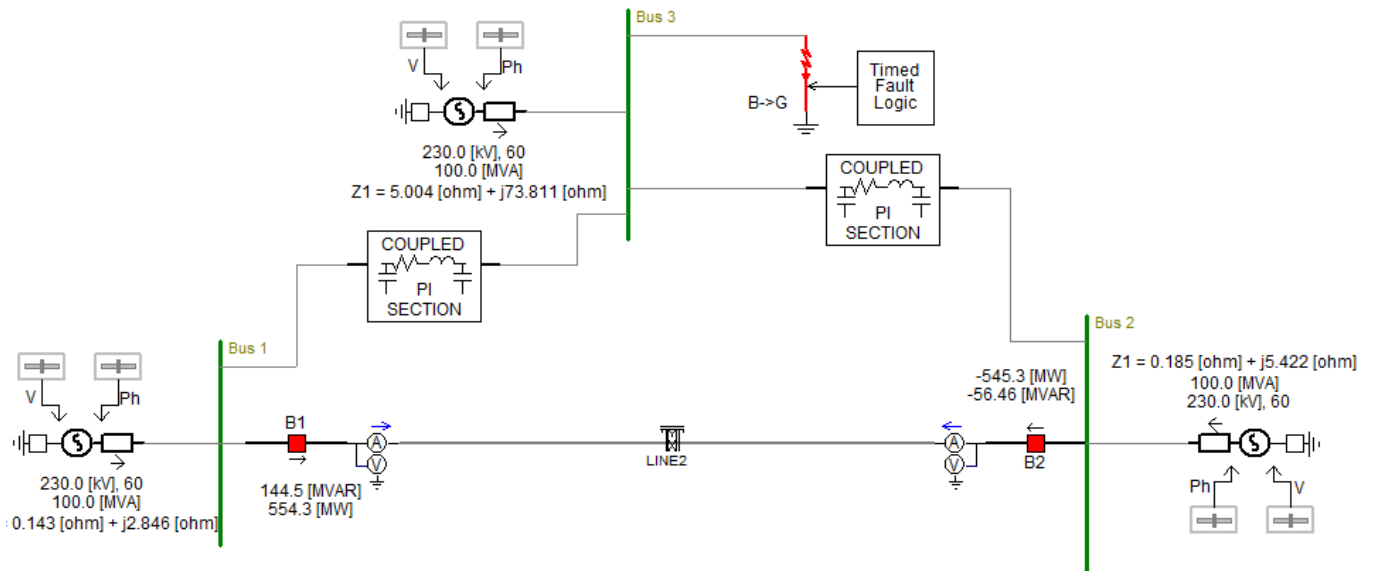

Fig. 4. PSCAD/EMTDC test setup and model for testing.

Because the line is transposed, there are three unknowns in the Y and Z matrices. Equations (13) and (14) can be used to solve for these parameters. One unbalanced condition seen by the line is required for the solution. This condition can be an external fault in the power system that generates enough zero-sequence voltage and current at the measurement locations. A measure for the unbalance is the ratio of positive-sequence current to zero-sequence current (I0/I1). The simulation was done with a close-in fault, moving the fault location away from the line under study. Good results were achieved with an I0/I1 ratio as low as 5 percent.

For the calculation of the Y matrix when we define (12), (7) takes on the form of (13).

$$I=I1+I2 \quad V=V1+V2 \quad (12)$$

$$I = VY \quad (13)$$

The Y matrix can be determined using matrix inversion. Similarly, Id from (9) can be calculated. If we define $V^0 = V1 - V2$, (8) becomes the following:

$$V^0 = Id \cdot Z \quad (14)$$

The Z matrix can also be solved for using matrix inversion.

2) Distributed Line Parameters

For the distributed line parameters, (10) can be solved for directly using numerical integration in the complex domain and a nonlinear iterative solution. Alternatively, (11) can be solved using a nonlinear iterative solution. The same line modeled in Fig. 4 was used for the calculation.

3) Results

Table I shows the line impedance comparison between the PSCAD/EMTDC simulation versus the equivalent PI circuit and distributed parameters.

TABLE I
LINE IMPEDANCE COMPARISON FOR TRANPOSED LINE

Calculation Method	Positive-Sequence Magnitude (primary ohms)	Positive-Sequence Angle (degrees)	Zero-Sequence Magnitude (primary ohms)	Zero-Sequence Angle (degrees)
PSCAD/ EMTDC simulation values	37.485	85.435	100.277	70.825
Equivalent PI circuit	37.43	85.457	101.93	71.433
Distributed parameters	37.536	85.444	101.868	71.324

A comparison between the equivalent PI circuit and distributed parameter calculations shows negligible difference, and both methods calculate the positive- and zero-sequence impedances accurately.

C. Untransposed Lines

Most transmission lines fall under this category, so developing a solution for untransposed lines is essential. The solution focuses on the equivalent PI circuit analysis. The distributed parameter line solution is complex and requires extensive calculation because there are 18 equations to solve for iteratively. In the case of a fully transposed line, there is no significant difference between the two methods.

Because we have more unknowns in the Y and Z matrices for untransposed lines compared with transposed lines, three independent states from the power system are needed to solve (13) and (14).

The conditions to solve (13) and (14) require (14) to have full rank. This can be achieved by having one state based on load conditions and two other states with an unbalanced condition. Similar to the transposed lines, the unbalanced condition does not have to occur on the untransposed line; it can occur anywhere in the power system that can generate unbalance. A measure of I0/I1 can indicate the amount of unbalance from the fault. Simulation results show even small unbalance (as low as 3 to 5 percent) can be used. The advantage of using three states (one from the load and two with unbalanced conditions) for the calculation is that remote faults in the system can be used for the calculation of the impedances and internal line faults are not required. The I and V equations from (13) and (14) represent A-, B-, and C-phase currents and voltages from three different states. The solution for Y and Z uses the generalized (pseudo) inverse matrix operation, which gives the least squares solution [8].

Table II shows the line impedance comparison between the PSCAD/EMTDC simulation values versus the equivalent PI circuit.

TABLE II
LINE IMPEDANCE COMPARISON FOR UNTRANPOSED LINE

Calculation Method	Positive-Sequence Magnitude (primary ohms)	Positive-Sequence Angle (degrees)	Zero-Sequence Magnitude (primary ohms)	Zero-Sequence Angle (degrees)
PSCAD/ EMTDC simulation values	15.021	85.435	40.184	70.825
Equivalent PI circuit	15.214	84.582	40.345	72.478

The results show that the calculation using the equivalent PI model for an untransposed line closely matches the actual line impedance used in the simulation.

IV. REAL TIME DIGITAL SIMULATOR SET UP AND RESULTS

A. General Overview

The structure of the network developed for validation testing is shown in Fig 5. The EMTDC/PSCAD model shown in Fig 4 was used and modeled in the RTDS to simulate the currents and voltages to be injected into the PMUs for different line lengths and tower configurations.

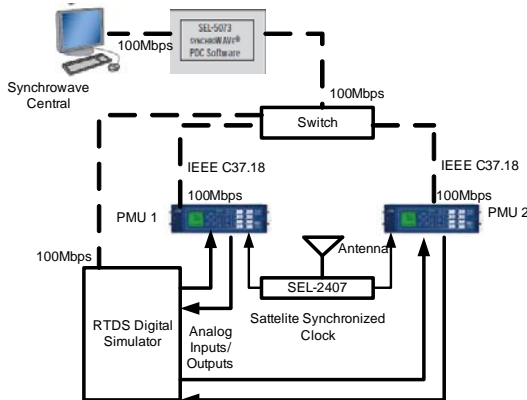

Fig. 5. RTDS and PMUs Network Set up for Validation Testing

B. Discussion and Summary of Results

1) Transposed Transmission Lines

Figures 6 and 7 show a summary graph of the results for the transposed transmission lines. The results for the transposed line cases of different tower configuration and ground resistivity are consistent. The percent error does not exceed 5 percent. These results validate the proposed method to be used for checking relay settings.

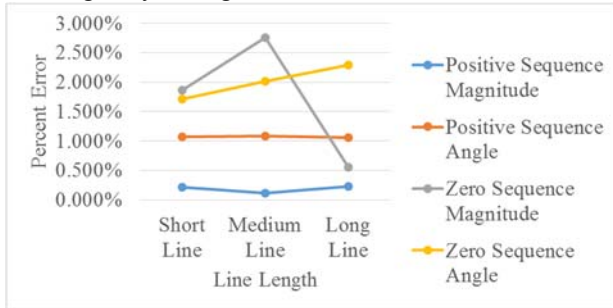

Fig. 6. Horizontal Tower Configuration Results

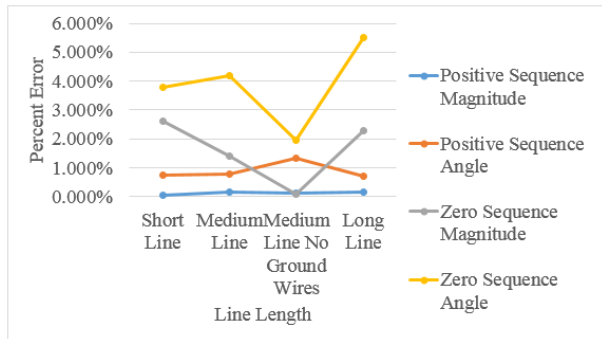

Fig. 7. Vertical Tower Configuration Results

2) Untransposed Transmission Lines

Figures 8 and 9 show a summary graph of the results for the untransposed transmission lines. In the case of untransposed lines for different tower configurations and ground resistivity, good results were obtained for the calculation of both positive- and zero-sequence impedances. The error did not exceed 5 percent. The exception is the vertical tower configuration for all line lengths. The error for both the positive-sequence magnitude and phase angle was high and identical around 20 percent. The zero-sequence parameters results were good and within 5 percent. Further investigation of the positive-sequence results revealed that the currents from the simulation software do not match the impedance matrix (15) given by the program's line constants. Figure 10 shows A-phase current is the highest in magnitude; however, (15) shows the self-impedance for B-phase is the lowest and should yield the highest magnitude current. The synchrophasor-derived values calculated the actual impedance based on the currents injected, but compared to the actual line impedance entered in the program, they do not agree. Further investigation of the root cause of this discrepancy needs to be followed up on with the manufacturer of the software.

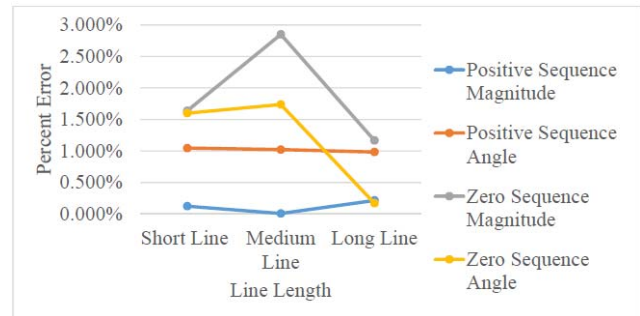

Fig. 8. Untransposed Lines Horizontal Tower Configuration Results

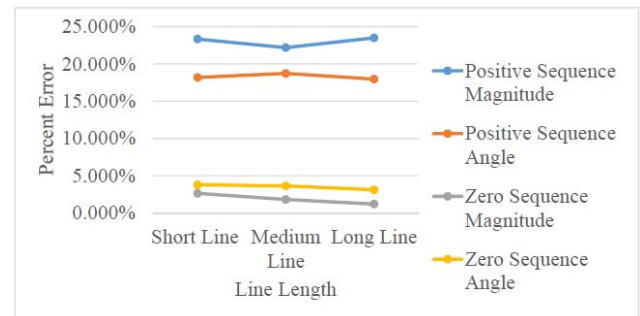

Fig. 9. Untransposed Lines Vertical Tower Configuration Results

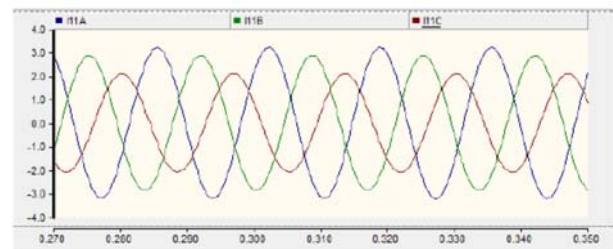

Fig. 10. PSCAD/EMTDC Simulation Results for Steady State Load Condition

$$Z = \begin{bmatrix} 11.864+53.187i & 10.058+25.505i & 9.565+21.827i \\ 10.058+25.505i & 13.357+51.594i & 10.288+25.25i \\ 9.565+21.827i & 10.288+25.25i & 12.283+52.714i \end{bmatrix} \quad (15)$$

V. CASE STUDY

Entergy received a Smart Grid Investment Grant (SGIG) from the U.S. Department of Energy and installed PMUs on multiple lines of their system as part of the Entergy PMU Hardening Project. The goal was to leverage the achievements and experience of the existing prototype Entergy system of phasors and reshape it into a wide-area monitoring system ready for operation. A transmission line with the setup shown in Fig. 11 was chosen to provide the data for this analysis. The untransposed line is 230 kV and 31 miles long. The PMUs installed are independent from the line protection. The data are retrieved and archived in a substation computer. Fig. 12 shows the setup and the requirements for the collection of data used in the calculation of relay parameters.

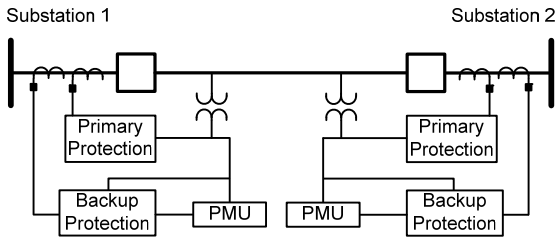

Fig. 11. PMU measurement diagram for the case study.

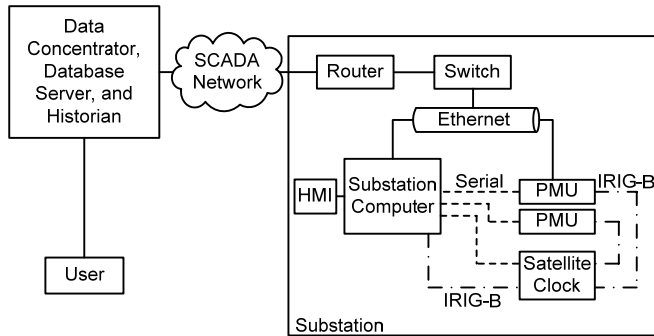

Fig. 12. PMU communication setup and diagram.

VI. CASE STUDY RESULTS AND DISCUSSION

Fig. 13 and Fig. 14 compare the calculated line impedances from three different line constants calculation (LCC) programs: Entergy LCC, PSCAD/EMTDC, and ASPEN LCC. The Entergy LCC was used to develop the settings. There is a slight difference between the positive-sequence impedance and the zero-sequence impedance. This can be attributed to how the LCC programs internally calculate these values and the assumptions made.

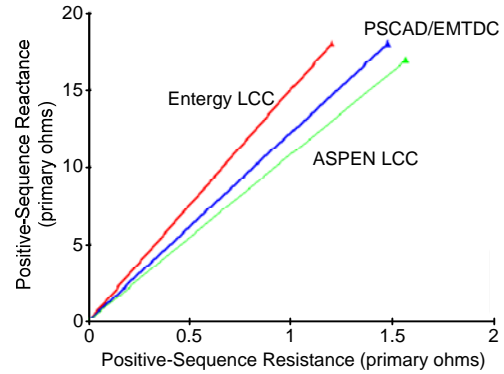

Fig. 13. Comparison of the positive-sequence impedance vectors calculated from the three LCC programs.

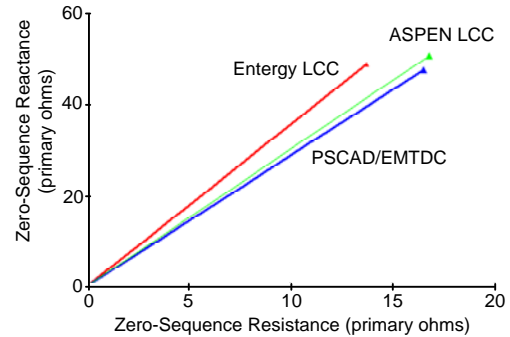

Fig. 14. Comparison of the zero-sequence impedance vectors calculated from the three LCC programs.

Fig. 15 and Fig. 16 compare the calculated line impedance of the three LCC programs and the line impedance derived from the synchrophasor measurements. The positive-sequence impedance measured by the synchrophasors closely matches that from the Entergy LCC. The zero-sequence impedance differs from the LCC programs, specifically the magnitude. Its percentage of error is about 19 percent; however, the zero-sequence angle is within 6 percent. This could be due to many factors, such as the earth resistivity assumption used in the LCC programs, current transformer (CT) errors, synchrophasor filtering and sampling, and fault duration that needs to be investigated further. However, the data are still useful for checking distance relay settings.

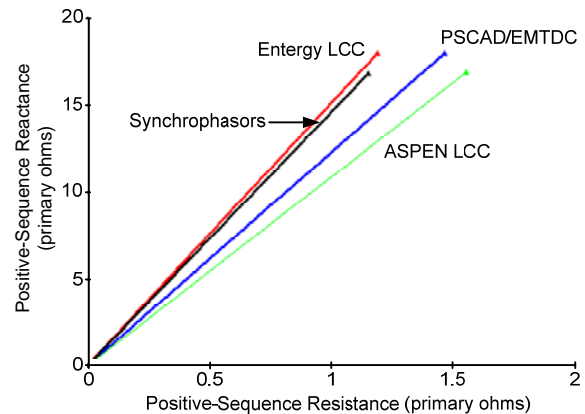

Fig. 15. Comparison of the positive-sequence impedance vectors calculated from the three LCC programs and synchrophasors.

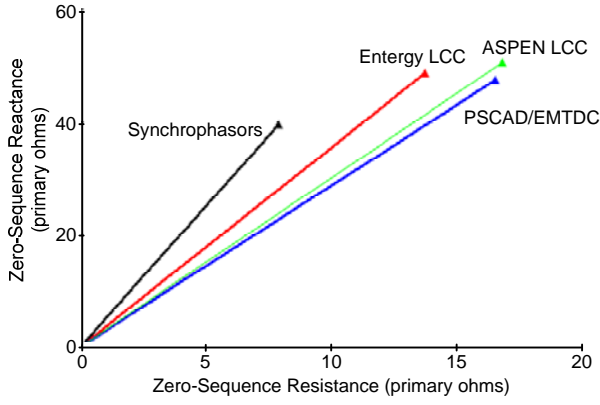

Fig. 16. Comparison of the zero-sequence impedance vectors calculated from the three LCC programs and synchrophasors.

Distance-based line protection uses positive-sequence impedance and a zero-sequence compensation factor k_0 , along with voltage and current measurements, to determine if faults are inside the protection zone. One method to estimate the distance to the fault for A-phase-to-ground faults by mho elements is provided in (16) [9].

$$mAG = \frac{\text{Re}(V_a \cdot V_{pol}^*)}{\text{Re}(Z_{1L} \cdot (I_a + k_0 \cdot I_G) \cdot V_{pol}^*)} \quad (16)$$

where:

V_a is the faulted phase voltage.

V_{pol} is the polarizing quantity.

I_a is the faulted phase current.

I_G is the residual current.

Z_{1L} is the positive-sequence line impedance.

k_0 is the zero-sequence compensation factor.

$$k_0 = \frac{Z_{0L} - Z_{1L}}{3Z_{1L}}$$

The zero-sequence compensation factor is the parameter used for the ground distance relay calculation. Fig. compares the zero-sequence compensation factor vectors calculated from the three LCC programs and the synchrophasor-based method.

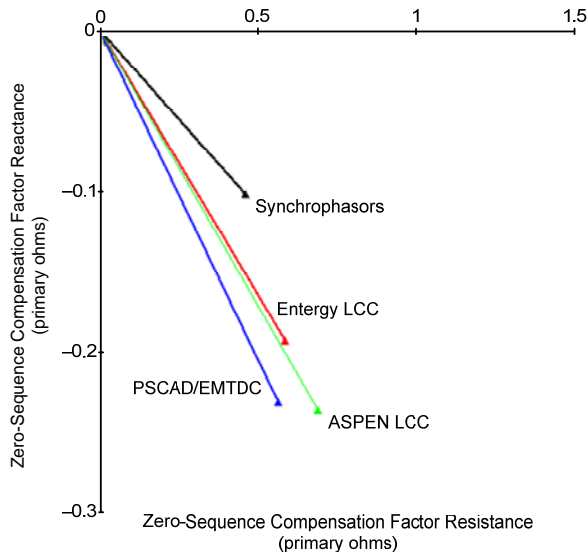

Fig. 17. Comparison of the zero-sequence compensation factor vectors calculated from the three LCC programs and synchrophasors.

The effect of both the LCC zero-sequence compensation factor and synchrophasor zero-sequence compensation factor on the distance element reach for the ground fault can be analyzed using (16). The per-unit reach along the line for both zero-sequence compensation factors is calculated for comparison. Fig. shows the results for a fault current with 80 degrees, lagging phase shift. The calculated Entergy LCC zero-sequence compensation factor reach at 80 percent of the line corresponds to a reach of 88 percent for the synchrophasor zero-sequence compensation factor. This result shows no overreach of the zone distance element.

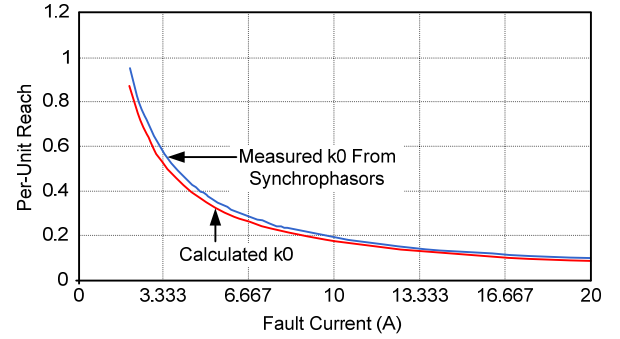

Fig. 18. Per-unit reach versus phase-to-ground fault current magnitude for calculated zero-sequence compensation factors from Entergy LCC and synchrophasors.

Table III through Table VI provide the settings for a proposed method for checking the relay settings from the synchrophasor data. The tables summarize the actual in-service settings of interest in the relay and compare them with the values derived from the synchrophasors. A difference between the two values above a threshold can be used to indicate a discrepancy. The goal of this is to minimize errors in the settings that can cause undesired operations, such as distance element overreach or underreach. Zone 1 should never overreach the remote terminal, and Zone 2 should always overreach. For Zone 1, if the measured impedance is less than the set relay reach, the reach should not exceed 5 to 10 percent of the measured impedance. The tolerance can be smaller if Zone 1 is set to 90 percent of the line versus 80 percent. The checking limit can be different based on the settings and their impact on the operation of the relay.

The calculation for both positive- and zero-sequence impedances requires three conditions from the power system (one steady state and two unbalance states). The positive-sequence impedance can be determined first from a steady state when the line is first put in service. The zero-sequence impedance can be estimated using historical data based on a ratio of positive-sequence impedance. Once the other two states of unbalance are made available by monitoring the 10/11 ratio, the calculations can be made for the validation and verification of relay settings based on the measurement.

TABLE III
RELAY TRANSMISSION LINE PARAMETERS

Relay Setting (secondary ohms)	In-Service Relay Setting	Synchrophasor-Derived Values	Error (%)	Suggested Checking Method (%)
Z1MAG	5.41	5.1	-5.73	Within ± 10
Z1ANG	86.24	86.1	-0.16	Within ± 5
Z0MAG	15.20	12.3	-19.08	Within ± 20
Z0ANG	74.35	78.735	5.90	Within ± 10

TABLE IV
PHASE DISTANCE ZONE SETTINGS

Relay Setting (secondary ohms)	In-Service Relay Setting	Synchrophasor-Derived Values	Error (%)	Suggested Checking Method (%)
Z1P	4.6	4.34	-5.73	Within ± 10
Z2P	7.1	6.69	-5.73	Within ± 10
Z3P	8.2	7.73	-5.73	Within ± 10
Z4P	15	14.14	-5.73	Within ± 10

TABLE V
GROUND DISTANCE ZONE SETTINGS

Relay Setting (secondary ohms)	In-Service Relay Setting	Synchrophasor-Derived Values	Error (%)	Suggested Checking Method (%)
Z1MG	4.6	4.34	-5.73	Within ± 10
Z2MG	7.1	6.69	-5.73	Within ± 10
Z3MG	8.2	7.73	-5.73	Within ± 10
Z4MG	15	14.14	-5.73	Within ± 10

TABLE VI
ZERO-SEQUENCE COMPENSATION FACTOR

Relay Setting (secondary ohms)	In-Service Relay Setting	Synchrophasor-Derived Values	Error (%)	Suggested Checking Method
k01M	0.613	0.5	-18.43	Within ± 0.1 ohms
k01A	-18.30	-12.527	-31.55	Within ± 5 degrees
Z2F	2.71	2.55	-5.90	Within ± 10
Z2R	2.81	2.65	-5.69	Within ± 10

VII. CONCLUSION

This paper presents a method to calculate the positive- and zero-sequence impedances for transposed and untransposed transmission lines using PMUs. These calculations are used to verify distance relay settings. The method for checking these calculations is presented along with the PMU data required for the calculation and system conditions. Simulations using PSCAD/EMTDC software were used to validate the results and verify the accuracy and limitations of the calculation method. The RTDS was used to further validate the performance in the presence of CTs and PTs and show the results from those calculations for different line length and tower configuration. The results from the RTDS confirmed the method used for the calculation and its accuracy.

The advantage of using this method to validate the settings is that it does not require additional changes to the line or conducting any tests or outages, as long as the line has a PMU that collects three-phase voltages and currents.

VIII. ACKNOWLEDGMENTS

The authors would like to acknowledge the assistance of graduate assistant Alaap Anujan for making and verifying the lab equipment connections for the RTDS testing.

IX. REFERENCES

- [1] D. Shi, D. J. Tylavsky, N. Logic, and K. M. Koellner, "Identification of Short Transmission-Line Parameters From Synchrophasor Measurements," proceedings of the 40th North American Power Symposium, Calgary, Canada, September 2008.
- [2] H. Z. Khorashadi and Z. Li, "A Novel PMU-Based Transmission Line Protection Scheme Design," proceedings of the 39th North American Power Symposium, Las Cruces, NM, September 2007.
- [3] K. Dasgupta and S. A. Soman, "Line Parameter Estimation Using Phasor Measurements by the Total Least Squares Approach," proceedings of the IEEE Power and Energy Society General Meeting, Vancouver, Canada, July 2013.
- [4] Z. Hu and Y. Chen, "New Method of Live Line Measuring the Inductance Parameters of Transmission Lines Based on GPS Technology," *IEEE Transactions on Power Delivery*, Vol. 23, Issue 3, July 2008, pp. 1288–1295.
- [5] S. E. Zocholl, "Sequence Components and Untransposed Transmission Lines." Available: http://www.pacw.org/fileadmin/doc/Sequence_Components_Untransposed_Lines.pdf.
- [6] A. P. S. Meliopoulos, *Power System Grounding and Transients: An Introduction*. Marcel Dekker, New York, NY, 1988.
- [7] A. R. Bergen and V. Vittal, *Power Systems Analysis*. Prentice Hall, Upper Saddle River, NJ, 2000.
- [8] *PTC Mathcad User's Guide*. MathSoft, Inc., Cambridge, MA, 1999.
- [9] H. J. Altuve Ferrer and E. O. Schweitzer, III (eds.), *Modern Solutions for Protection, Control, and Monitoring of Electric Power Systems*. Schweitzer Engineering Laboratories, Inc., Pullman, WA, 2010.